



**CITY OF DEL REY OAKS
ENCROACHMENT/STREET OPENING PERMIT**

Date: _____ Application No. _____

Property Owner: _____ Phone No.: _____

Property Address: _____

Mailing Address (if different): _____

Owner hereby applies for a permit for the purpose of construction (build, change, or break) on City Property.

Description of Work: (Include square footage, dimensions, and estimate of dollar value of job)

Applicant agrees that work will be done in accordance with existing City Ordinances and that he/she will comply with the General Conditions listed on the attachment.

Signature of Applicant: _____ Date: _____

For Office Use Only

(Circle all that apply)

Permit is approved: YES NO

Permit is approved with special conditions of approval which are a part of the permit: YES NO

Permit application is referred to the City Council for their considerations and action: YES NO

Authorized by: _____ Date: _____

Note: Your approved application is the permit. Payment must be received prior to processing.

CITY OF DEL REY OAKS

As condition for the granting of an encroachment permit from the City of Del Rey Oaks, I hereby agree to the following conditions:

GENERAL CONDITIONS

1. **Hold Harmless:** Permittee shall indemnify, defend, and hold the City of Del Rey Oaks, its officers, employees and agents harmless against any and all losses or damages, claims or suits, from any cause whatever, arising directly or indirectly from the City's issuance or revocation of this permit or from the construction, maintenance or existence of the encroachment permitted pursuant to this permit.
2. **Maintenance:** Permittee shall at all times maintain the public property covered by this permit and any structures or landscaping placed thereon in a safe, neat and attractive manner. Upon completion of the work permitted pursuant to this permit, permittee shall to the satisfaction of the city and at the permittee's sole cost and expense restore the public property to at least as good a condition as the public property existed prior to the permittee's commencement of work.
3. **Revocability:** This permit shall be revocable at any time without cause unless otherwise specified. The City shall give written notice of such revocation and a reasonable time to remove the encroachment at the permittee's sole cost and expense. Permittee agrees to remove the encroachment after said notice and to restore the public property to a safe condition and as nearly as practicable to its condition prior to the commencement of work. If permittee fails to do so, the City may do said work, either with its own employees or by private contract and the permittee shall be liable for said costs.
3. **Transferability:** This permit is for the benefit of the adjacent property (other than temporary encroachments) and may be transferred to the successor of the permittee without consent of the City, provided, however, that no transfer of this permit shall become effective until the transferee accepts the terms and condition of the permit. It shall be the duty of the permittee to notify the City and to notify his/her successor of this permit and the terms and conditions herein.
5. **Signs:** There shall be no sign of other forms of advertising within the area covered by this permit unless specifically authorized by the City.
6. **Inspection Notice:** Prior to any construction activity the applicant shall contact the City of Del Rey Oaks for a field inspection of the work to be done within the public right-of-way. A twenty-four (24) hour notice shall be given to the City of Del Rey Oaks prior to any work activity.
7. **Insurance:** Permittee shall obtain and maintain throughout the term of this permit, public liability and property damage insurance at a combined single limit per occurrence of \$1 million and a general

aggregate limit of \$2 million. Such policy shall cover on an occurrence or an accident basis and not on a claims made basis. Such insurance shall name the City of Del Rey Oaks and its officers, employees, and agents as additional insureds by endorsement.

NOTICE TO CONTRACTORS

THIS IS A LIST OF SPECIFIC REQUIREMENTS FOR STREET OPENINGS.AND ENCROACHMENTS, INCLUDING CURB OR SIDEWALK CUTS, GUTTERS, AND DRIVEWAYS.

1. NOTIFICATION OF WORK:

The Contractor shall call the City prior to starting any project. Telephone No. 394-8511.

2. ALL, repeat ALL lateral connections will be made by installation of a "Wye" (Y).

3. TRAFFIC CONTROL SAFETY AND WARNING DEVICES:

The Contractor must provide barricades, signs and/or flagmen to secure work site during construction. Detours or other impediments to a normal flow of traffic shall have prior approval of the City Engineer or the Police Department.

4. BACKFILL AND COMPACTION:

No backfilling will be commenced until the work has been inspected by a City official.

Open cut trenches may be backfilled with materials excavated only with the approval of the City Engineer.

Materials unsuitable for backfill must be disposed of by the Contractor and imported materials approved by the Street Superintendent shall be used.

Backfill shall be compacted in lifts not exceeding six (6) inches, with air tamper, trench plate vib-compactor or other acceptable compaction methods.

5. CUTTING STREET SURFACES:

All concrete and asphalt streets will be saw cut with smooth, straight edges.

6. UNCOMPLETED STREET OPENINGS:

Where openings cannot be completed during the day of opening, suitable barriers shall be placed around the excavation to prevent accidents, and lighted barricades shall be continuously maintained at the opening site. Steel or wooden plates will be placed over trench if traffic would otherwise be impeded.

7. ARCHEOLOGICAL FINDS:

In the event that any archeological finds (building ruins, utensils, tools, bones, etc.) are encountered, all excavating is to cease immediately and the City is to be notified.

STANDARD DETAIL FOR RESIDENTIAL DRIVEWAY IN STREET RIGHT OF WAY

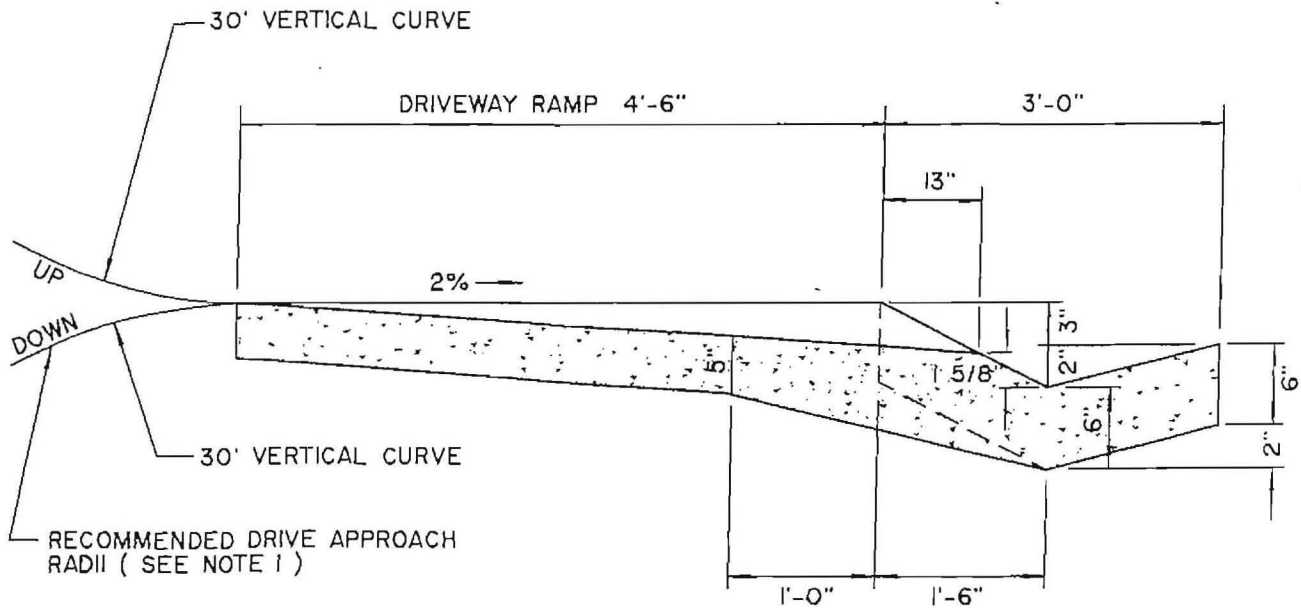

TYPICAL SECTION

NOTES:

- I. DRIVEWAYS BEYOND PROPERTY LINE OR BACK OF SIDEWALK LINE SHOULD BE FITTED THROUGH A 30' VERTICAL CURVE TO A MAX. GRADE OF 15%.

CITY OF DEL REY OAKS

STANDARD DETAILS FOR STREET IMPROVEMENTS

DESIGNED BY	TITLE RESIDENTIAL DRIVEWAY SECTION		
DRAWN BY CB	APPROVED <i>Clayton B. Keeler</i>	DATE APR. 10, 2002	DETAIL No. ..
CHECKED BY	CITY ENGINEER	RCE NO. 12805	